



*Cattle Control Equipment*

# Assembly Instructions

**Milker Cart**

*Model MC55*

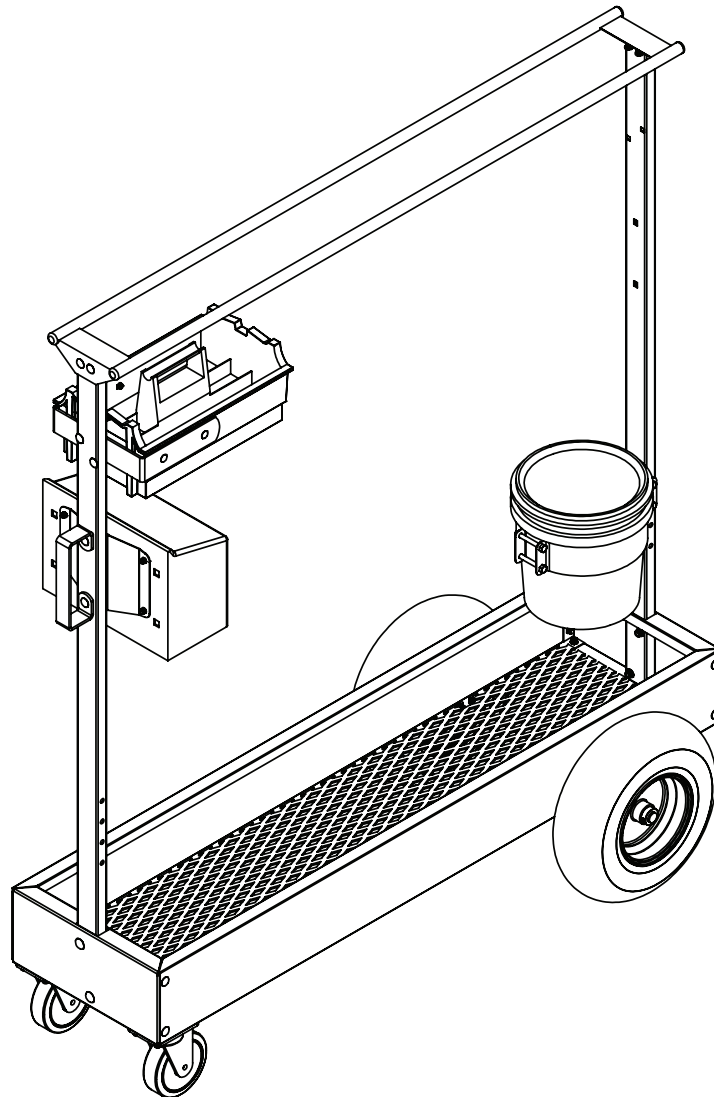

**PBZ LLC | 295 Wood Corner Rd | Lititz PA 17543**  
**www.zimmermanequipment.com | (717) 738-7365**

*A Paul B Zimmerman Inc. Company*

**Form OM0012**

*Rev. Date 4/10*



# MC55 Box Contents

The milker cart, model MC55, comes disassembled in a box and requires assembly. Follow the step-by-step instructions to ensure proper assembly. Before assembling, ensure that the box contains all of the necessary components and parts.

**Table 1: Standard Milker Cart Kit (pages 4–7)**

Ref	Qty.	Part Number	Description
A	1	MC5501	Front box panel
B	1	MC5502	Rear box panel
C	1	MC5503	Right box panel
D	1	MC5504	Left box panel
E	1	MC5505	Floor grate
F	1	MC5506	Axle shaft
G	2	MC5507	Vertical post
H	1	MC5508	Top rail
I	1	MC5509	Cart handle
J	1	MC5510	Tray mounting bracket
K	12	FN38	Flange nut, 3/8-16
L	18	FN516	Flange nut, 5/16-18
M	4	FN14	Flange nut, 1/4-20
N	1	311R	Plastic tray w/ drawer
O	8	CB38*34	Carriage bolt, 3/8-16 x 3/4"
P	4	CB14*34	Carriage bolt, 1/4-20 x 3/4"
Q	4	CB38*112	Carriage bolt, 3/8-16 x 1 1/2"
R	6	CB516*112	Carriage bolt, 5/16-18 x 1 1/2"
S	2	CB516*134	Carriage bolt, 5/16-18 x 1 3/4"
T	4	PPR7/8*10-14	Poly plug, round, 7/8" OD x 10-14ga
U	10	CBS516*12	Carriage bolt, short neck, 5/16-18 x 1/2"
V	2	MW40062	400x6 air tire,
W	4	0750P	Shaft collar, 3/4"
X	2	TP505L	Caster, 5" swivel
Y	2	N222400	U-bolt, 1/4" x 3/4" x 1 1/2"

**Table 2: Bucket Holder Kit (optional) (page 8)**

Ref	Qty.	Part Number	Description
A	2	MC5511	Bucket holder bracket
B	4	H5C516*212	Hex bolt, 5/16-18 x 2 1/2"
C	4	FN516	Flange nut, 5/16-18
D	1	N/A	Bucket (not included)

**Table 3: Towel Dispenser Kit (optional) (page 8)**

Ref	Qty.	Part Number	Description
E	1	MC5512	Towel dispenser mounting bracket
F	4	CB14*12	Carriage bolt, 1/4-20 x 1/2"
G	4	FN14	Flange nut, 1/4-20
H	1	631P	Towel dispenser

# MC55 Assembly Instructions

## Assembly Instructions

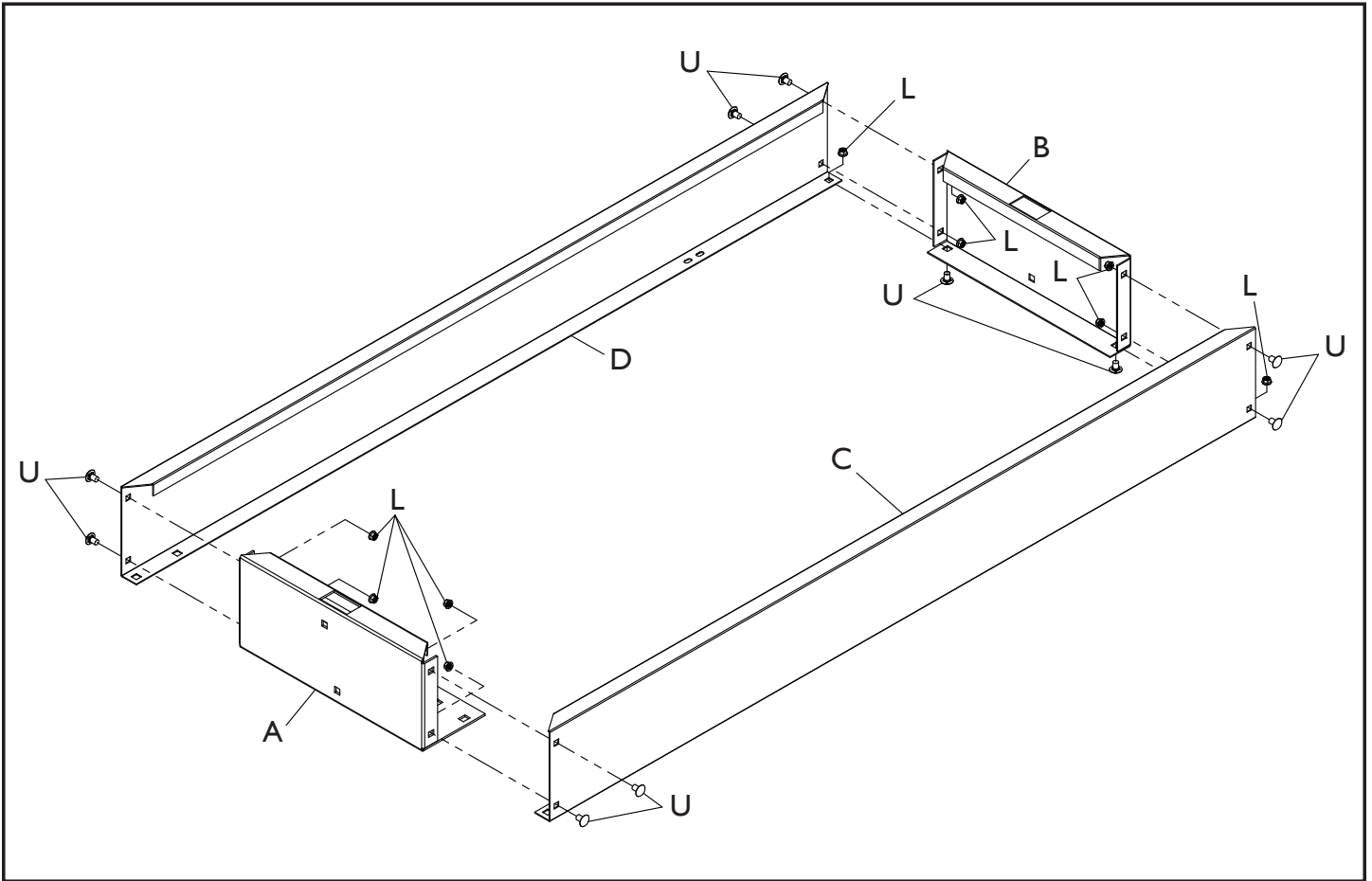

# MC55 Assembly Instructions

## Assembly Instructions

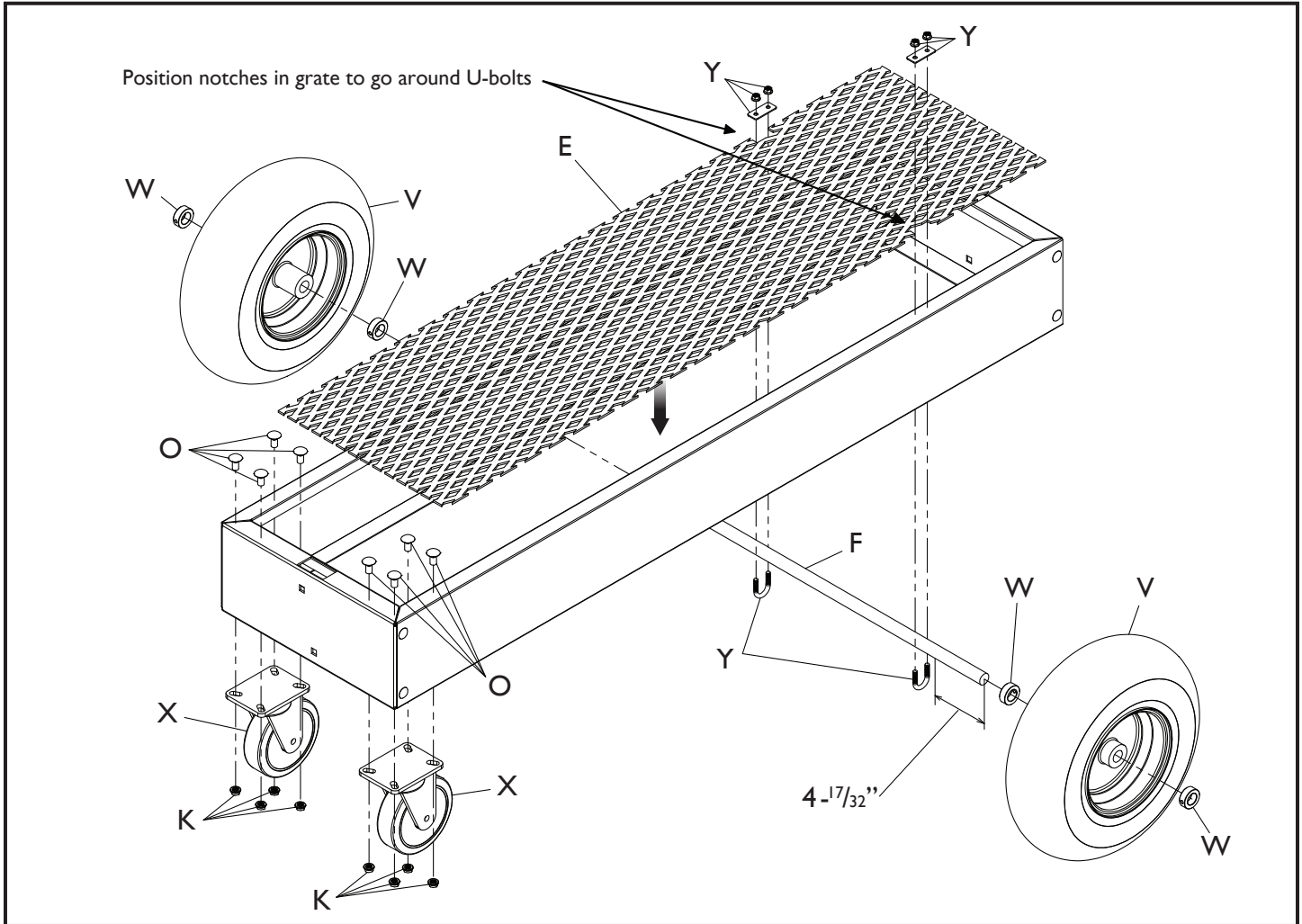

**Note:** The axle shaft must be centered relative to the bottom frame. The distance from each end of the axle shaft to the outside of the side panel should be  $4\text{ }^{-17}/_{32}\text{''}$  (as shown).

**Note:** The two shaft collars (W) on the inside of the wheels (V) should be positioned directly against the frame panel.

# MC55 Assembly Instructions

## Assembly Instructions

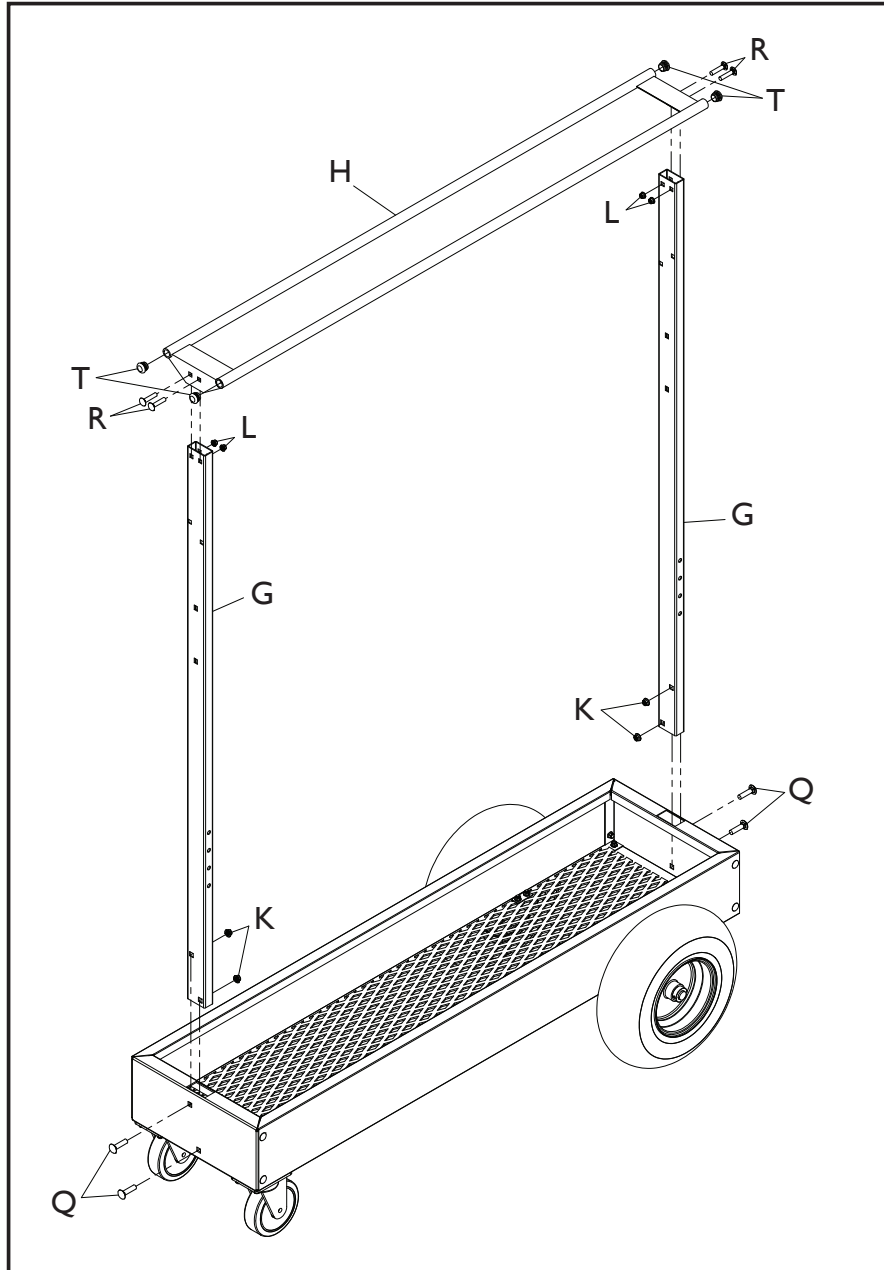

# MC55 Assembly Instructions

## Assembly Instructions

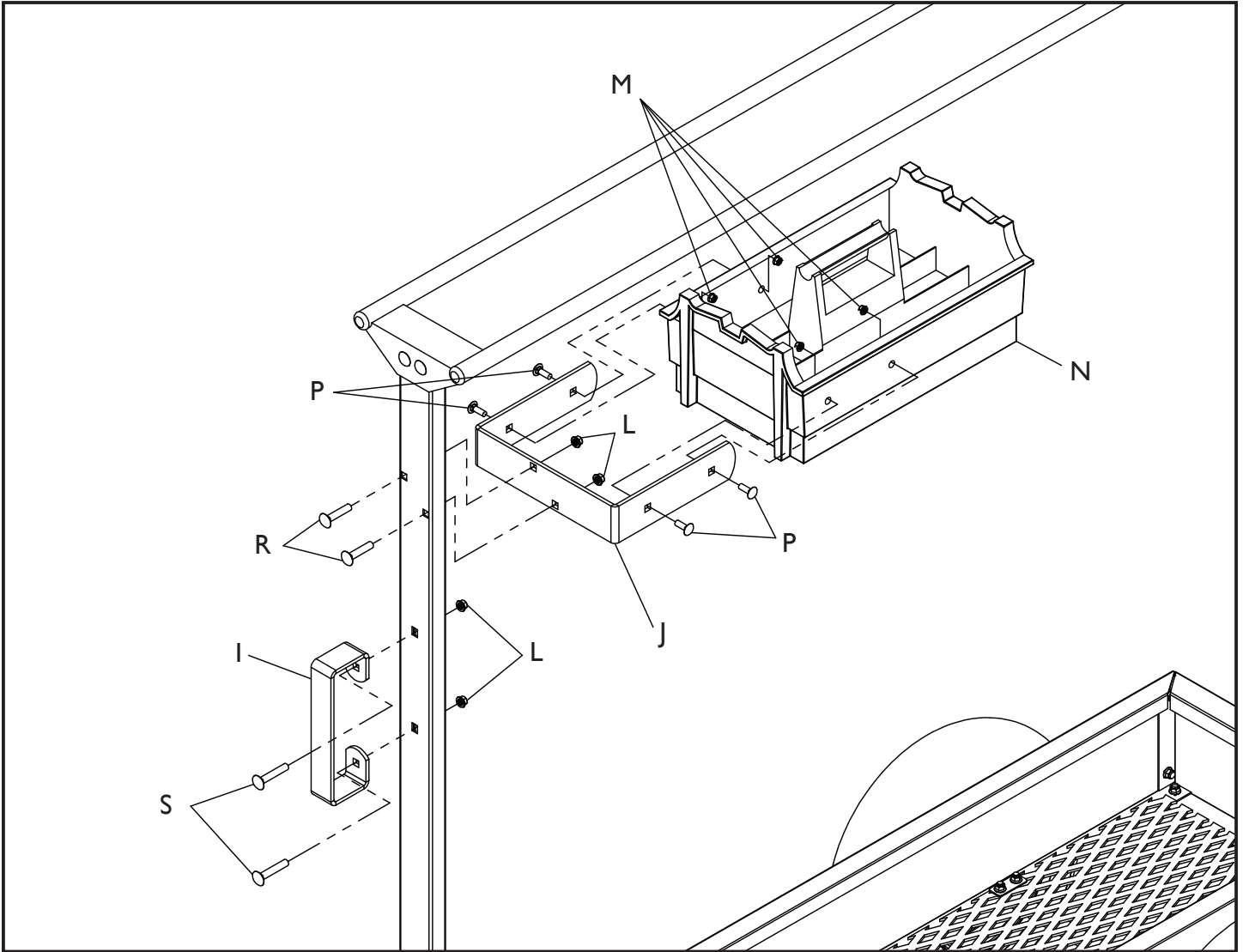

# MC55 Accessory Assembly Instructions

## Assembly Instructions

