



***Cattle Control Equipment***

# **Owner's Manual**

**Cattle Chute**

*Model ECC12*

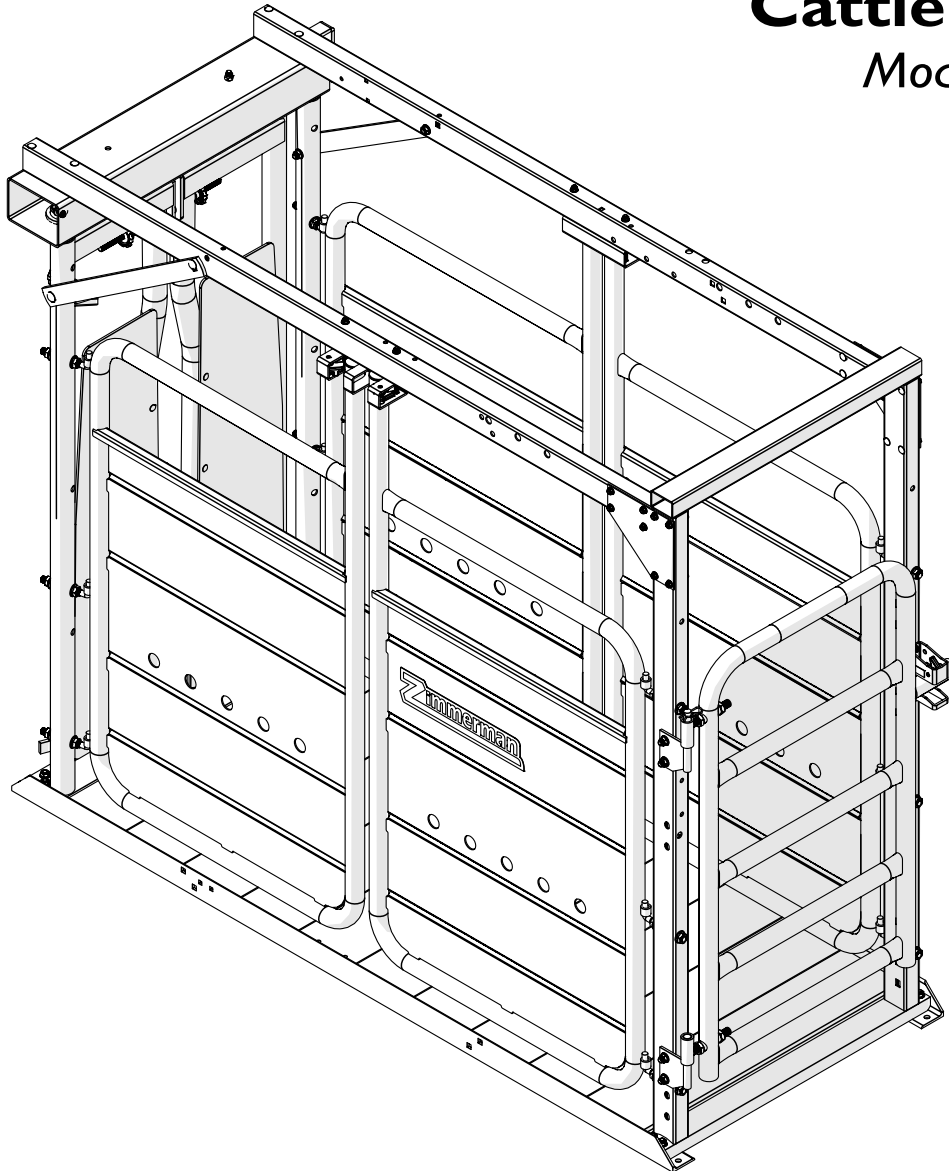

**PBZ LLC | 50 Wood Corner Rd | Lititz PA 17543**  
**www.zimmermanequipment.com | (717) 738-7365**

*A Paul B Zimmerman Inc. Company*

**Form OM0020**  
*Rev. Date 12/11*



Zimmerman Equipment would like to thank you for choosing to purchase one of our cattle control chutes. We appreciate your business and want to fill all of your cattle control equipment needs. We also desire to provide you with the technical support and needed parts that will allow you to continue operating without disruption. For parts and service please contact your local Zimmerman Equipment dealer.

# Table Of Contents

<b>Safety Precautions .....</b>	<b>3</b>
General Guidelines.....	3
<b>Operating Instructions .....</b>	<b>4</b>
Before Loading the Animal.....	4
Loading the Animal.....	4
Operation.....	4
Releasing the Animal.....	4
<b>Zimmerman Equipment Limited Warranty .....</b>	<b>5</b>
<b>Contact Us.....</b>	<b>6</b>
Ordering Parts.....	6

# Safety Precautions



## General Guidelines

- Be sure to read and understand this entire manual before attempting to operate the cattle chute.
- Remember that all animals are dangerous and can behave unpredictably. Treat each animal with respect regardless of the temperament of the animal.
- The cattle chute is not intended for use with bison, or any animal with horns exceeding 18” in width.
- Check all bolts before each use to be sure they are tight.
- Make sure the cattle chute is properly anchored to the floor or another stable structure.
- When loading an animal into the cattle chute, always stand clear of the front of the chute in case the doors do not lock properly.
- Keep fingers clear of all latch and hinge points.
- Never allow children to play in or around the cattle chute.

# Operating Instructions

## Before Loading the Animal

1. Be sure that the rear gate (a) is fully open and clear of the path of the animal (Figure 1).
2. Be sure the chute is clear of any obstructions.
3. The headgate doors must be in the loading position and must be properly adjusted to accommodate the size of the animal being loaded (See the Automatic Headgate owner's manual for instructions).

## Loading the Animal

1. The animal should approach from the rear of the chute as shown (Figure 1).
2. For slow or timid animals, the headgate features a handle (a) to manually close the doors (Figure 2).
3. If the animal puts its head through the headgate but does not go far enough for the doors to close, the handle can be pulled to manually close and lock the doors in place (See the Automatic Headgate owner's manual for details).

Note: See the Automatic Headgate owner's manual for instructions on releasing an animal that gets caught by the ribs in the headgate.

4. After the animal is in the chute, close the rear gate.

Note: If the animal enters the chute but resists going far enough to lock the headgate you may need to close the rear gate to prevent it from backing out of the chute.

## Operation

1. If the operator needs to access the animal from the rear, the animal can be locked in place by sliding a pipe through the holes in the side gates.
2. Slide a pipe (anything smaller than a 1.50" diameter) through the holes in the gates behind the back legs of the animal. This will prevent the animal from backing out of the chute or kicking the operator (Figure 3).
3. The side gates can also be opened to access the animal from the side (Figure 4).

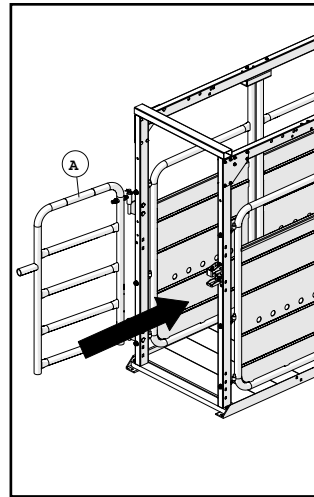

Figure 1: Loading the animal

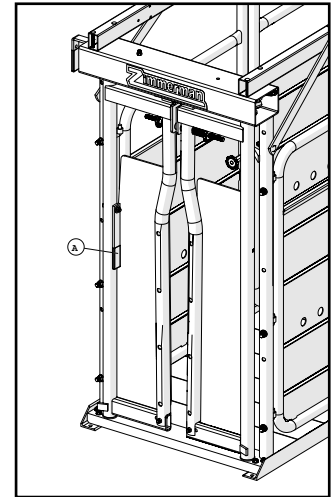

Figure 2: Manual door handle

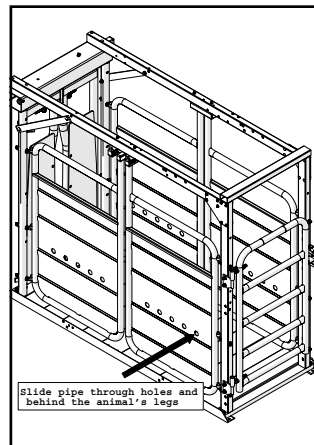

Figure 3: Holes in gates

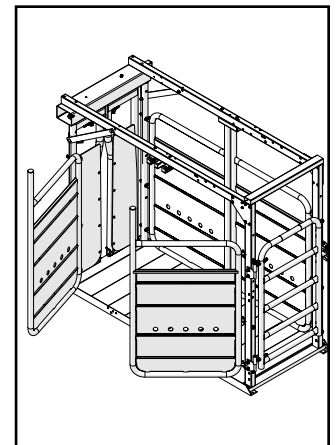

Figure 4: Side gates in use

## Releasing the Animal

1. After all operations are complete, make sure that all obstructions are completely removed and clear of the animal's path of exit from the chute.
2. Release the animal from the headgate (See Automatic Headgate owner's manual for instructions).

# Zimmerman Equipment Limited Warranty

**Vet Care Chute: Model ECC12**

## Warranty Coverage

PBZ LLC hereby provides a Limited Two (2) Year Warranty on cattle chutes, manufactured by PBZ LLC. Cattle chutes manufactured by PBZ LLC are warranted against any manufacturer's defects in any of the chute's components in the 24 months following the original date of purchase.

Defective components will be repaired or replaced at the discretion of the manufacturer. It is the responsibility of the purchaser to return warranted components to the manufacturer. This warranty is limited to the repair or replacement of cattle chute components only. PBZ LLC is not to be held liable for incidental or consequential damages of any kind. This warranty covers the purchaser of this cattle chute and any other owners who own it during the two year warranty period.

To retain the warranty, the cattle chute must be operated and maintained as ascribed by its owner's manual. For warranty service, please have a copy of the purchase invoice available.

## Warranty Is Void if:

1. The cattle chute has been subjected to, in the opinion of PBZ LLC, negligent handling, misuse, an accident or if the instructions in the owner's manual were not completely followed.
2. The cattle chute's components have been altered in any manner or repairs have taken place with unapproved parts.

## Getting Service

All cattle chute warranty claims must be made through an authorized Zimmerman Equipment dealer. All warranty claims must be submitted with an invoice or a proof of purchase that denotes the purchase date and place of purchase. If you have any questions or comments concerning this warranty, please contact an authorized Zimmerman Equipment dealer.

# Contact Us

We desire to give you continuing service in the best manner possible. This includes listening to your comments, suggestions, and problems. We will do our best to answer all questions thoroughly and in a timely manner. We have trained customer service specialists who are more than willing to listen to any questions or problems and help you to find a feasible solution.

## Ordering Parts

We have a fully-stocked parts department that will be able to meet all of your parts needs. Our trained customer service specialists will ensure that all purchases are processed smoothly and shipped in a timely manner. We regularly ship our parts and products on the same business day and we are willing to work with you to find the best shipping solution. We also offer priority shipping to reduce your downtime and keep your Zimmerman equipment on the job.

**Note:** When ordering parts, please provide our sales staff with the correct part number and description listed on the parts list.



### **PBZ LLC**

A Paul B Zimmerman Inc. Company

50 Wood Corner Road

Lititz PA 17543

(717) 738-7365

Fax (717) 738-7375

[www.zimmermanequipment.com](http://www.zimmermanequipment.com)